

REVELATOR

TWEETER

D2904/710002

The Revelator Tweeters large roll surround technology represents a breakthrough in overall performance, with outstanding off-axis response, high output capability and low resonance frequency. Additional enhancements have been made to reduce distortion and power compression, such as large neodymium magnet systems for high sensitivity, and a careful design to optimise airflow in the chambers.

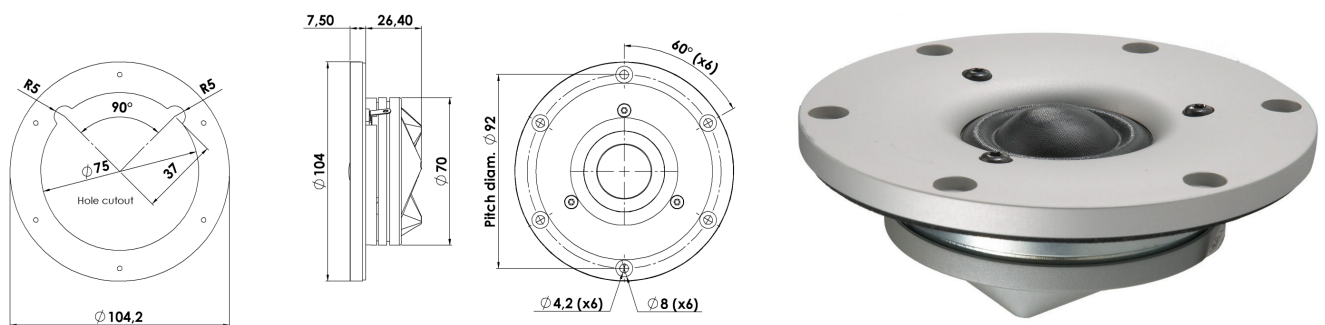

KEY FEATURES:

- 1" Coated Textile Diaphragm
- Patented Symmetrical Drive (SD-2) motor
- Non Resonant Alu Rear Chamber
- Large Roll Surround f. Wide Dispersion
- Large Ring Neo Magnet f. High Output
- Silver Anodized Machined Alu Face Plate

T-S Parameters

Resonance frequency [fs]	520 Hz
Mechanical Q factor [Qms]	3.50
Electrical Q factor [Qes]	0.50
Total Q factor [Qts]	0.44
Force factor [Bl]	2.8 Tm
Mechanical resistance [Rms]	0.37 kg/s
Moving mass [Mms]	0.4 g
Suspension compliance [Cms]	0.23 mm/N
Effective diaph. diameter [D]	30 mm
Effective piston area [Sd]	7 cm ²
Equivalent volume [Vas]	0.02 l
Sensitivity (2.83V/1m)	94.4 dB
Ratio Bl/√Re	1.62 N/√W
Ratio fs/Qts	1189 Hz

Notes:

IEC specs. refer to IEC 60268-5 third edition.
 All Scan-Speak products are RoHS compliant.
 Data are subject to change without notice.
 Datasheet updated: January 29, 2011.

Electrical Data

Nominal impedance [Zn]	4 Ω
Minimum impedance [Zmin]	3.7 Ω
Maximum impedance [Zo]	24.0 Ω
DC resistance [Re]	3 Ω
Voice coil inductance [Le]	0.01 mH

Power Handling

100h RMS noise test (IEC 17.1)*	90 W
Long-term max power (IEC 17.3)*	150 W

*Filter: 2. order HP Butterworth, 2.5 kHz

Voice Coil and Magnet Data

Voice coil diameter	26 mm
Voice coil height	2.1 mm
Voice coil layers	2
Height of gap	2.5 mm
Linear excursion	± 0.2 mm
Max mech. excursion	± 1.6 mm
Unit weight	0.4 kg



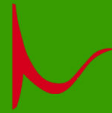

REVELATOR

TWEETER

D2904/710002

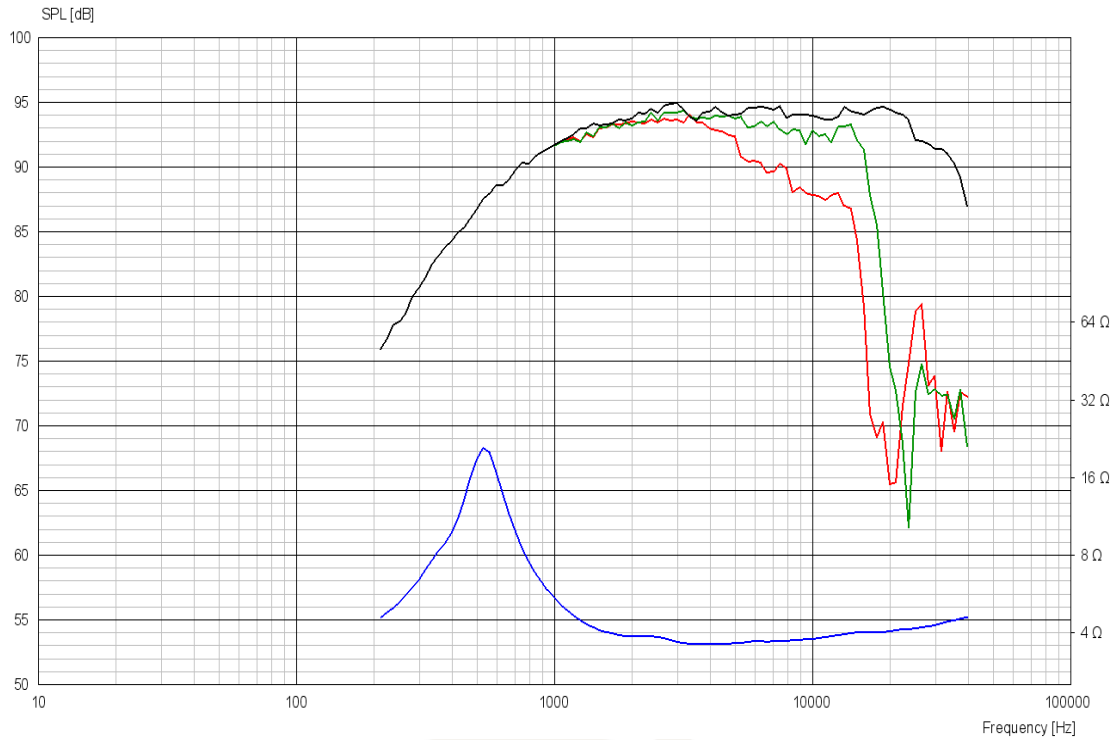

Advanced Parameters (Preliminary)

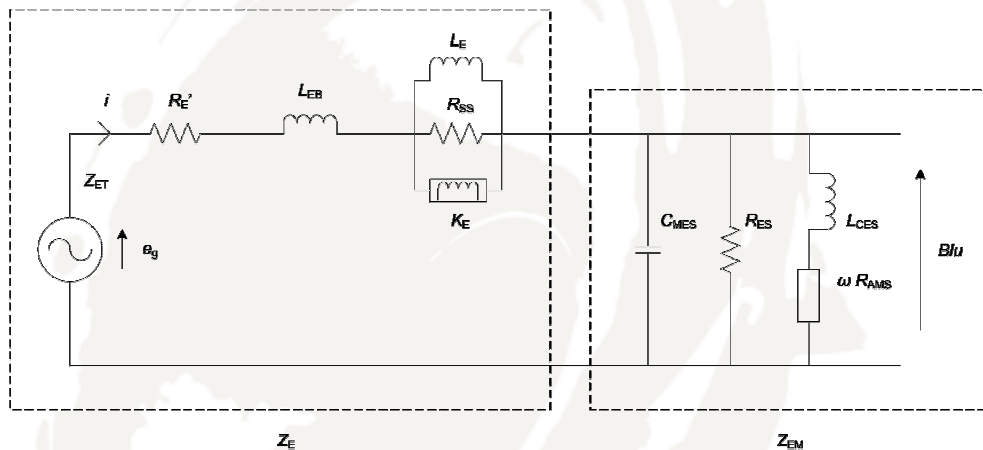

Electrical data:

Resistance [Re']	- Ω
Free inductance [Leb]	- mH
Bound inductance [Le]	- mH
Semi-inductance [Ke]	- SH
Shunt resistance [Rss]	- Ω

Mechanical Data

Force Factor [Bl]	- Tm
Moving mass [Mms]	- g
Compliance [Cms]	- mm/N
Mechanical resistance [Rms]	- kg/s
Admittance resistance [Rams]	- mΩ·s

