

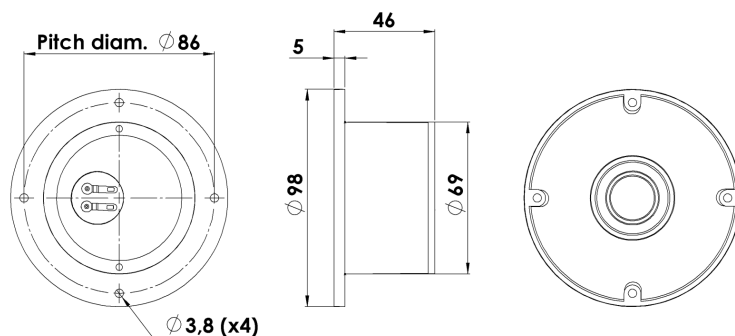

## TWEETER

## D2010/851100

The 3/4" tweeters D2008 and D2010 are among the many highly praised designs in Classic series. They have enjoyed success for more than 35 years. And still among the best tweeters available.



### KEY FEATURES:

- 3/4" Textile Dome Diaphragm
- Diffraction Damping Foam Front
- Wide Dispersion
- Dual Rear Chamber

#### T-S Parameters

Resonance frequency [fs]	650 Hz
Mechanical Q factor [Qms]	1.90
Electrical Q factor [Qes]	0.81
Total Q factor [Qts]	0.57
Force factor [Bl]	2.4 Tm
Mechanical resistance [Rms]	0.43 kg/s
Moving mass [Mms]	0.2 g
Suspension compliance [Cms]	0.30 mm/N
Effective diaph. diameter [D]	22 mm
Effective piston area [Sd]	3.8 cm <sup>2</sup>
Equivalent volume [Vas]	0.01 l
Sensitivity (2.83V/1m)	89 dB
Ratio Bl/√Re	1.01 N/√W
Ratio fs/Qts	1147 Hz

#### Notes:

IEC specs. refer to IEC 60268-5 third edition.  
All Scan-Speak products are RoHS compliant.  
Data are subject to change without notice.  
Datasheet updated: January 29, 2011.

#### Electrical Data

Nominal impedance [Zn]	8 $\Omega$
Minimum impedance [Zmin]	7.1 $\Omega$
Maximum impedance [Zo]	19.1 $\Omega$
DC resistance [Re]	5.7 $\Omega$
Voice coil inductance [Le]	0.08 mH

#### Power Handling

100h RMS noise test (IEC 17.1)*	90 W
Long-term max power (IEC 17.3)*	150 W

\*Filter: 2. order HP Butterworth, 4 kHz

#### Voice Coil and Magnet Data

Voice coil diameter	19.4 mm
Voice coil height	3.2 mm
Voice coil layers	2
Height of gap	1.7 mm
Linear excursion	$\pm 0.8$ mm
Max mech. excursion	$\pm 1.2$ mm
Unit weight	0.4 kg



# TWEETER

# D2010/851100

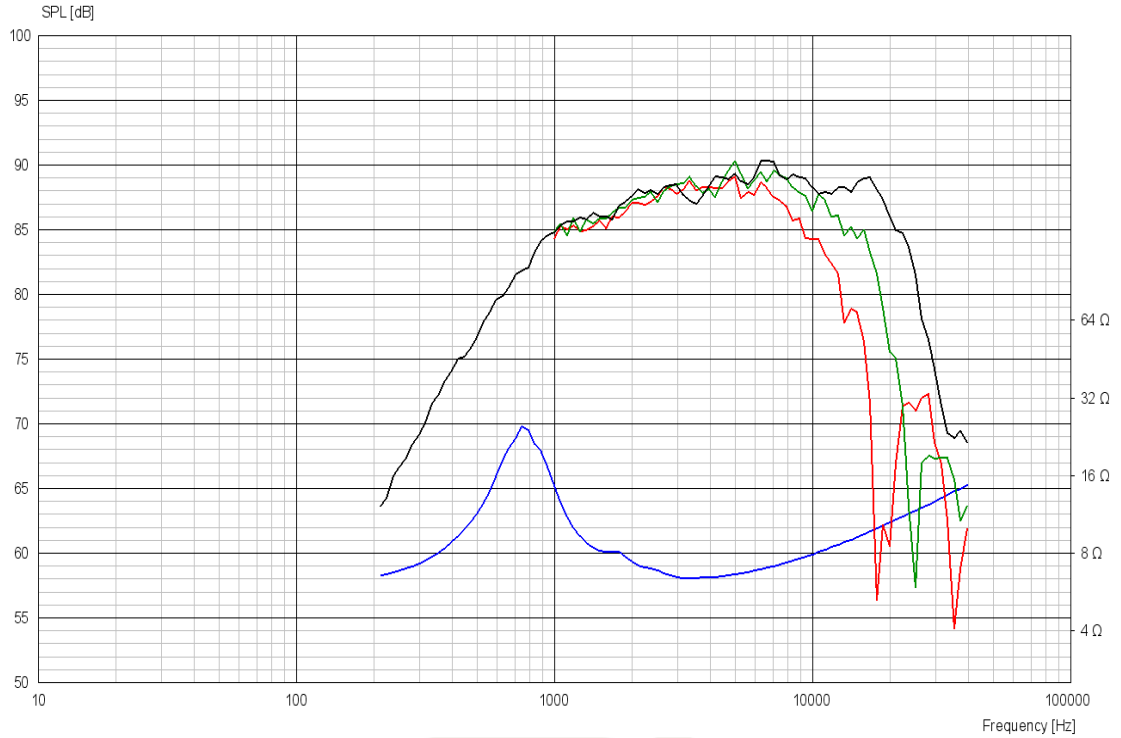

## Advanced Parameters (Preliminary)

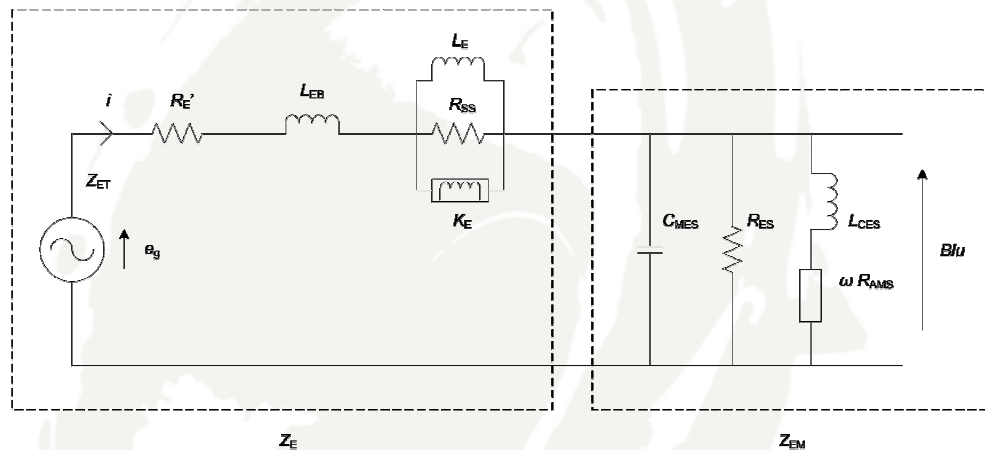

### Electrical data:

Resistance [Re']	- Ω
Free inductance [Leb]	- mH
Bound inductance [Le]	- mH
Semi-inductance [Ke]	- SH
Shunt resistance [Rss]	- Ω

### Mechanical Data

Force Factor [BI]	- Tm
Moving mass [Mms]	- g
Compliance [Cms]	- mm/N
Mechanical resistance [Rms]	- kg/s
Admittance resistance [Rams]	- mΩ·s