

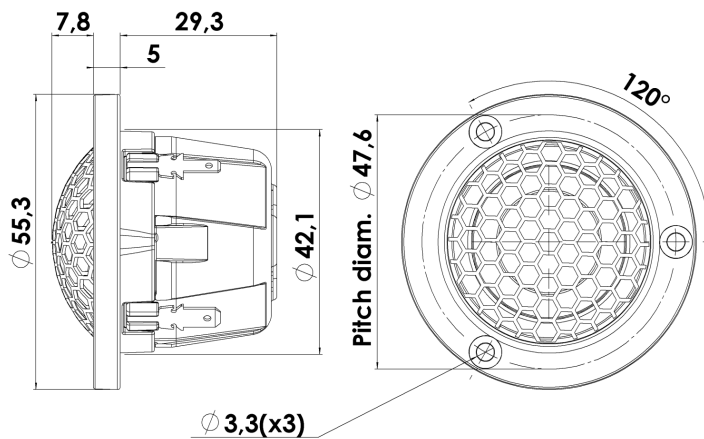

## TWEETER

## D2004/602000

The compact size is one of the key elements of these Illuminator tweeters, which provides a high degree of flexibility within design options. The small size is employed without compromising sound quality where these compact tweeters are fully comparable to the renowned full size Illuminator and Revelator tweeters, no matter if the music is played at high or low listening levels.



### KEY FEATURES:

- 3/4" Textile Dome Diaphragm
- Patented Symmetrical Drive (SD-2) motor
- Non Resonant Alu Rear Chamber
- Large Roll Surround f. Wide Dispersion
- Sound Transparent Protective Grill
- Die Cast Housing & Face Plate

#### T-S Parameters

Resonance frequency [fs]	600 Hz
Mechanical Q factor [Qms]	4.42
Electrical Q factor [Qes]	1.42
Total Q factor [Qts]	1.07
Force factor [Bl]	1.3 Tm
Mechanical resistance [Rms]	0.2 kg/s
Moving mass [Mms]	0.22 g
Suspension compliance [Cms]	0.32 mm/N
Effective diaph. diameter [D]	24 mm
Effective piston area [Sd]	4.5 cm <sup>2</sup>
Equivalent volume [Vas]	0.01 l
Sensitivity (2.83V/1m)	88.4 dB
Ratio Bl/√Re	0.78 N/√W
Ratio fs/Qts	558 Hz

#### Notes:

IEC specs. refer to IEC 60268-5 third edition.  
All Scan-Speak products are RoHS compliant.  
Data are subject to change without notice.  
Datasheet updated: January 29, 2011.

#### Electrical Data

Nominal impedance [Zn]	4 Ω
Minimum impedance [Zmin]	3.4 Ω
Maximum impedance [Zo]	11.5 Ω
DC resistance [Re]	2.8 Ω
Voice coil inductance [Le]	0.02 mH

#### Power Handling

100h RMS noise test (IEC 17.1)*	50 W
Long-term max power (IEC 17.3)*	120 W

\*Filter: 2. order HP Butterworth, 3 kHz

#### Voice Coil and Magnet Data

Voice coil diameter	19 mm
Voice coil height	1.8 mm
Voice coil layers	2
Height of gap	2.5 mm
Linear excursion	± 0.4 mm
Max mech. excursion	± 1.6 mm
Unit weight	0.15 kg



# TWEETER

# D2004/602000

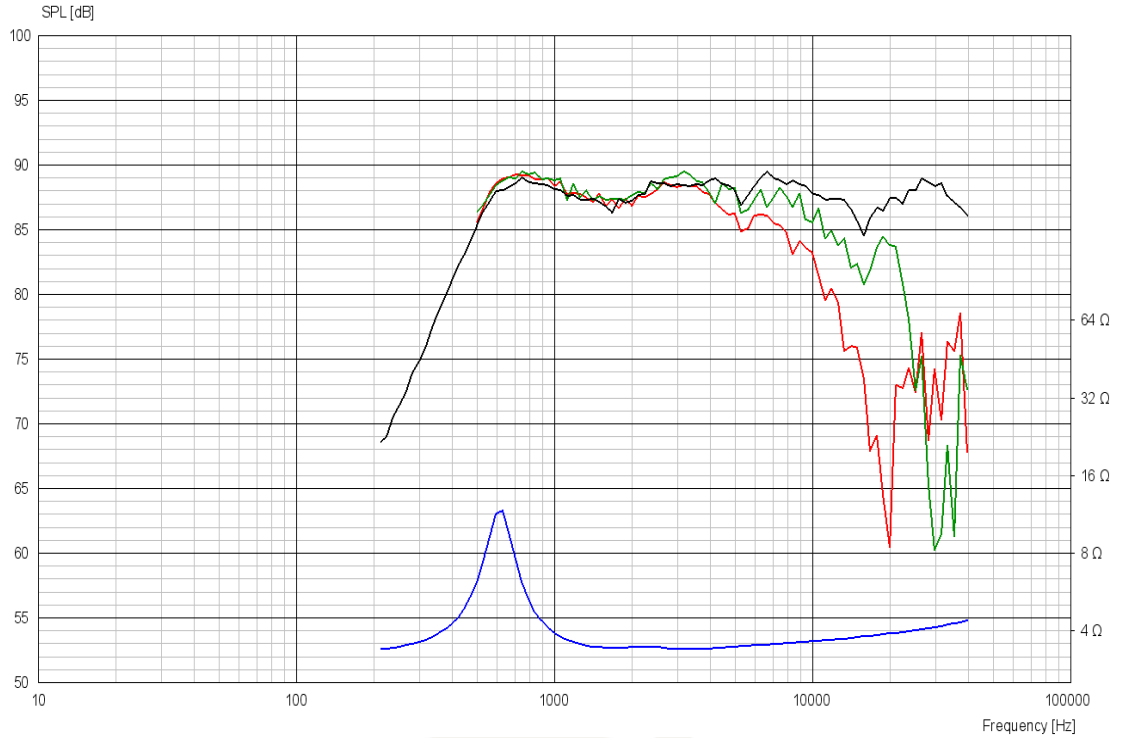

## Advanced Parameters (Preliminary)

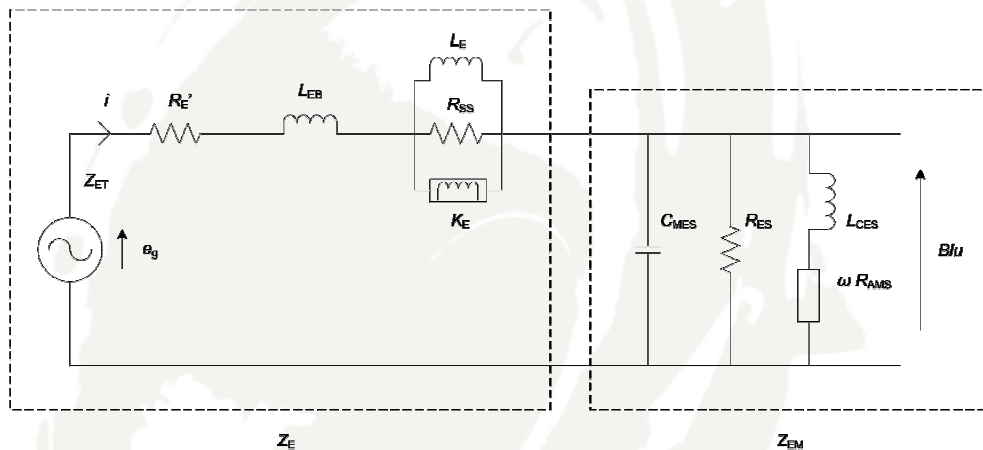

### Electrical data:

Resistance [Re']	- Ω
Free inductance [Leb]	- mH
Bound inductance [Le]	- mH
Semi-inductance [Ke]	- SH
Shunt resistance [Rss]	- Ω

### Mechanical Data

Force Factor [Bl]	- Tm
Moving mass [Mms]	- g
Compliance [Cms]	- mm/N
Mechanical resistance [Rms]	- kg/s
Admittance resistance [Rams]	- mΩ·s