

# REVELATOR

## SUBWOOFER

## 32W/4878T00

The 32W/4878T00 is the most powerful sub woofer designed by Scan-speak to this date, with its large 3" voice coil, extreme linear excursion and low resonance frequency is it perfect to reproduce the deepest frequencies. It features a brand new type of paper-sandwich cone with a special foam filling technology (patented) that gives the cone very high stiffness and relative low weight. The motor system has heavy duty copper sleeves for optimizing eddy currents and minimizing self-induction.

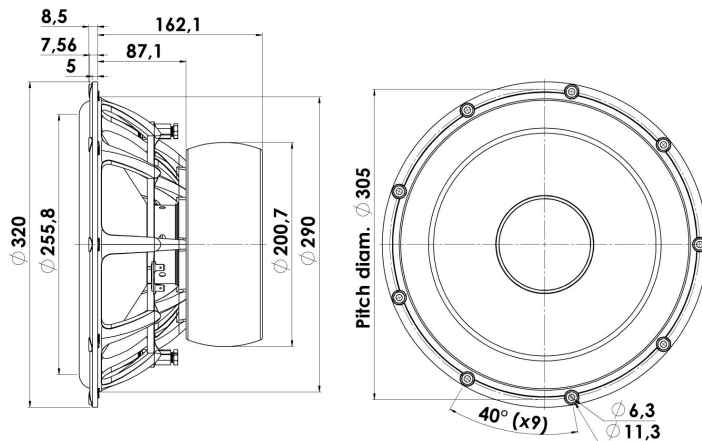

### KEY FEATURES:

- Paper sandwich cone with Patented foam filling
- Patented Symmetrical Drive motor
- Spider with balanced woven in tinsel leads
- Extreme linear excursion (+/-14 mm)
- 3" Voice coil, Titanium former and paper reinforced
- Stiff and strong die cast aluminium chassis

#### T-S Parameters

Resonance frequency [fs]	18 Hz
Mechanical Q factor [Qms]	7
Electrical Q factor [Qes]	0.33
Total Q factor [Qts]	0.32
Force factor [Bl]	12.5 Tm
Mechanical resistance [Rms]	2.42 kg/s
Moving mass [Mms]	150 g
Compliance [Cms]	0.52 mm/N
Effective diaph. diameter [D]	260 mm
Effective piston area [Sd]	531 cm <sup>2</sup>
Equivalent volume [Vas]	207.5 l
Sensitivity (2.83V/1m)	90 dB
Ratio Bl/√Re	7.1 N/√W
Ratio fs/Qts	56.3 Hz

#### Notes:

IEC specs. refer to IEC 60268-5 third edition.  
All Scan-Speak products are RoHS compliant.  
Data are subject to change without notice.  
Datasheet updated: 02.11.2012

#### Electrical Data

Nominal impedance [Zn]	4 Ω
Minimum impedance [Zmin]	4 Ω
Maximum impedance [Zo]	69 Ω
DC resistance [Re]	3.1 Ω
Voice coil inductance [Le]	0.5 mH

#### Power Handling

100h RMS noise test (IEC 17.1)	350 W
Long-term max power (IEC 17.3)	1000 W

#### Voice Coil & Magnet Data

Voice coil diameter	75 mm
Voice coil height	36 mm
Voice coil layers	2
Height of gap	8 mm
Linear excursion	± 14 mm
Max mech. excursion	± 28 mm
Unit weight	7.5 kg



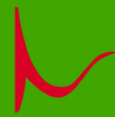

# REVELATOR

## SUBWOOFER

## 32W/4878T00

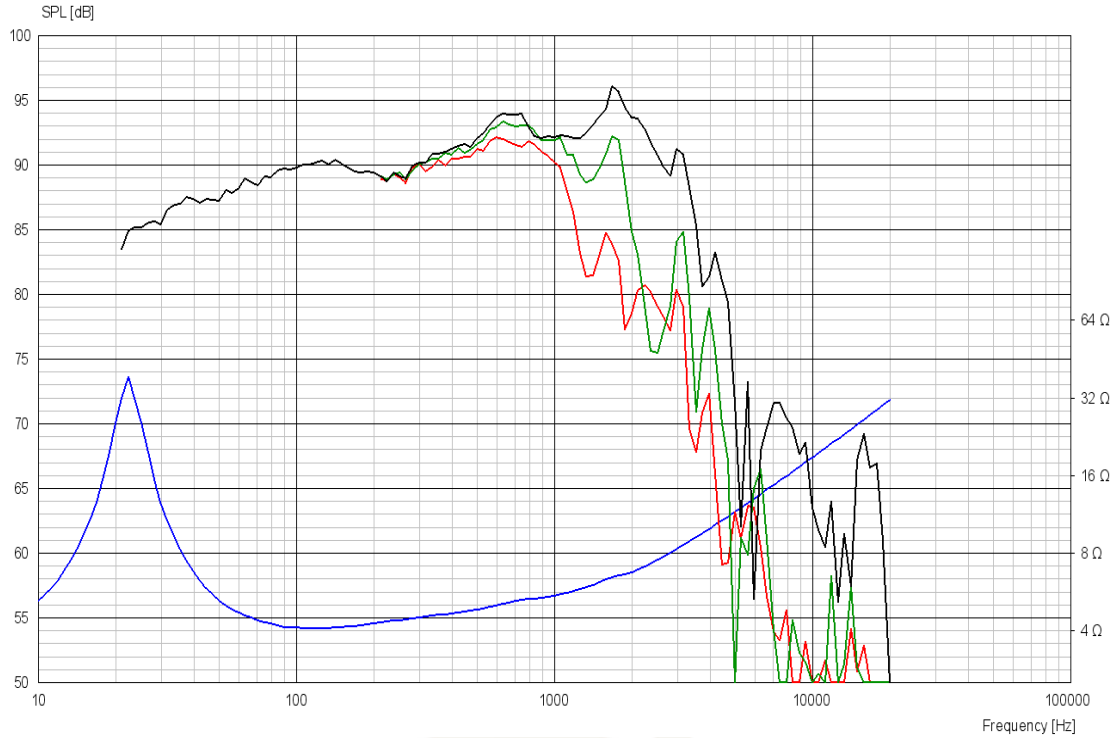

### Advanced Parameters (Preliminary)

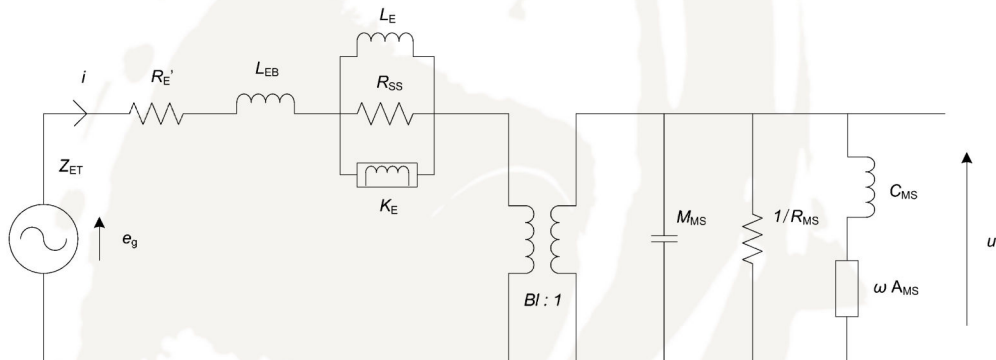

#### Electrical data

Resistance [Re']	3.11 Ω
Free inductance [Leb]	2.74 mH
Bound inductance [Le]	0.008 mH
Semi-inductance [Ke]	0.046 SH
Shunt resistance [Rss]	4.47 Ω

#### Mechanical Data

Force Factor [BI]	12.47 Tm
Moving mass [Mms]	146.7 g
Compliance [Cms]	0.657 mm/N
Mechanical resistance [Rms]	2.70 kg/s
Admittance [Ams]	0.096 mm/N

